

# Development of a Constant Acceleration Mössbauer Spectrometer for Environmental Research

Charles Harrington and Michael Vineyard

Department of Physics and Astronomy

## Introduction

Mössbauer spectroscopy is a technique used to make very precise measurements of shifts in nuclear energy levels. These shifts provide information about the chemical, structural, and magnetic properties of the material in which the nucleus resides. This technique has been applied to a broad range of scientific investigations—from the measurement of the gravitational red-shift predicted by Einstein’s theory of general relativity [1] to the study of soil samples collected by the Mars space rover [2].

## Theory

An atomic nucleus can absorb a gamma ray if the energy of the gamma ray is equal to the energy difference between two states of the nucleus. This is known as resonant absorption. A nucleus can also emit a gamma ray when it undergoes a transition from a state of high excitation energy to a state of lower energy. If the nucleus is free, it will recoil when it emits the gamma ray due to the conservation of momentum, and the total energy of the gamma ray and recoiling nucleus will be equal to the energy difference of the two nuclear states. In this case the gamma ray would not have enough energy to be absorbed by another nucleus of the same type undergoing a transition between the same states, and resonant absorption would be suppressed.

In 1957, Rudolf Mössbauer [3] showed that if the emitting and absorbing nuclei are bound in lattices, the recoil energy is reduced so that resonant absorption can be observed. Relative motion between the emitter and the absorber with velocities on the order of millimeters per second will Doppler shift the energy of the gamma ray and destroy the resonant absorption. Very small shifts in nuclear energy levels due to the environment of the nucleus can be measured by determining the relative velocity at which resonant absorption is observed.

These small shifts can be explained by three phenomena: Isomer shift, quadrupole splitting, and magnetic splitting.

## Iron-57

There are two requirements for an element to be a Mössbauer source. It must emit a low energy gamma ray and have a relatively long-lived excited state [3]. The gamma ray emitted by the nucleus must be low in energy so as not to cause a phonon, or vibration in the lattice. Successful recoilless emission and absorption requires the whole lattice to recoil rather than a small part.

Next, a long-lived excited state means a small spectral linewidth for the transition. The relationship between this linewidth and the energy of the gamma ray gives us the resolution we need to examine the miniscule change in nuclear transitions, or hyperfine interactions.

Iron-57 is the most studied Mössbauer nucleus because it fits these requirements and is the fourth most abundant element in nature [4], catering to environmental research. It emits a low energy gamma ray of 14.4-keV and this transition has a small linewidth of  $5 \times 10^{-12}$ -keV [3]. From these two values we calculate a resolution of 1 part in  $10^{12}$ —like measuring the distance from the Earth to the Moon to within the thickness of a piece of paper.

Our source consists of cobalt-57 embedded in rubidium, forming the necessary crystal lattice. But, we probe with iron-57, which we gain from nuclear decay. As seen in Figure 1, cobalt transforms to iron by electron capture. The Mössbauer gamma ray is given off by a transition from the spin 3/2 excited state to the spin 1/2 ground state.

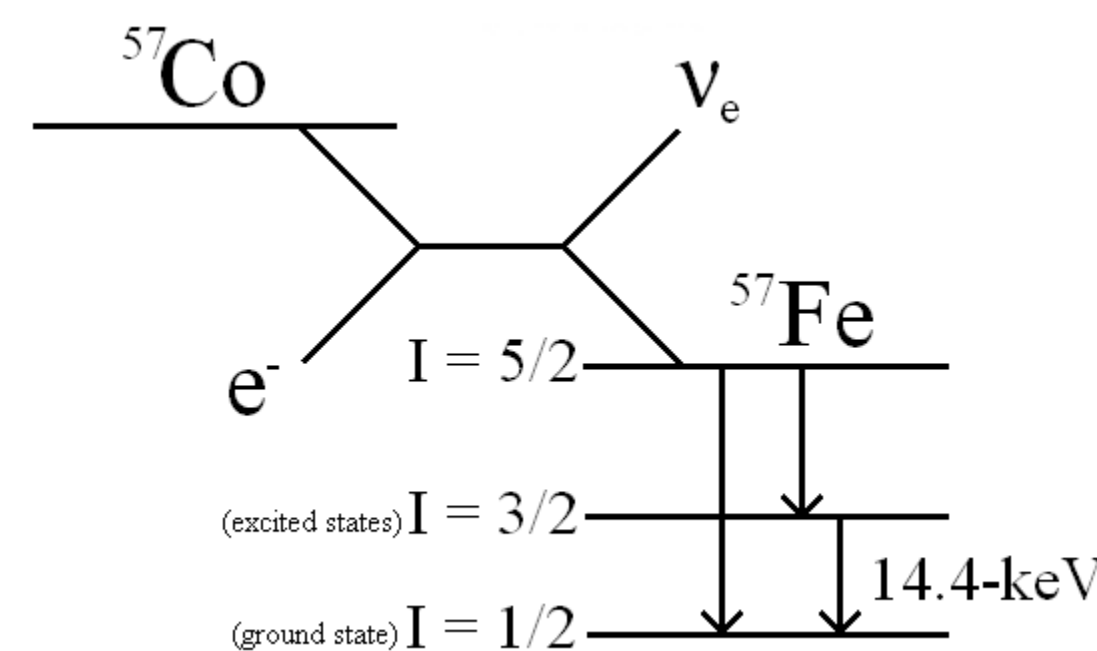

Figure 1: Energy level diagram showing the decay of  $^{57}\text{Co}$  to  $^{57}\text{Fe}$  through electron capture. We are interested in the gamma ray given off by the transition from the first excited state to the ground state of  $^{57}\text{Fe}$ .

## Isomer Shift

A shift in a nuclear energy level caused by a change in the interaction of the electron cloud with the nucleus is called an isomer shift [3]. As shown in Figure 2, the ground and excited states shift. This shift reveals details about the bonding and shielding of iron atoms in the material.

## Quadrupole Splitting

A nuclear quadrupole moment occurs in nuclei with non-spherical charge distributions. In the presence of an electric field gradient, or non-uniform electric field, nuclear energy levels may be split [3]. The splitting for the first excited state in  $^{57}\text{Fe}$  is shown in Figure 2. Measuring the splitting provides information about the electron configuration of iron in the material.

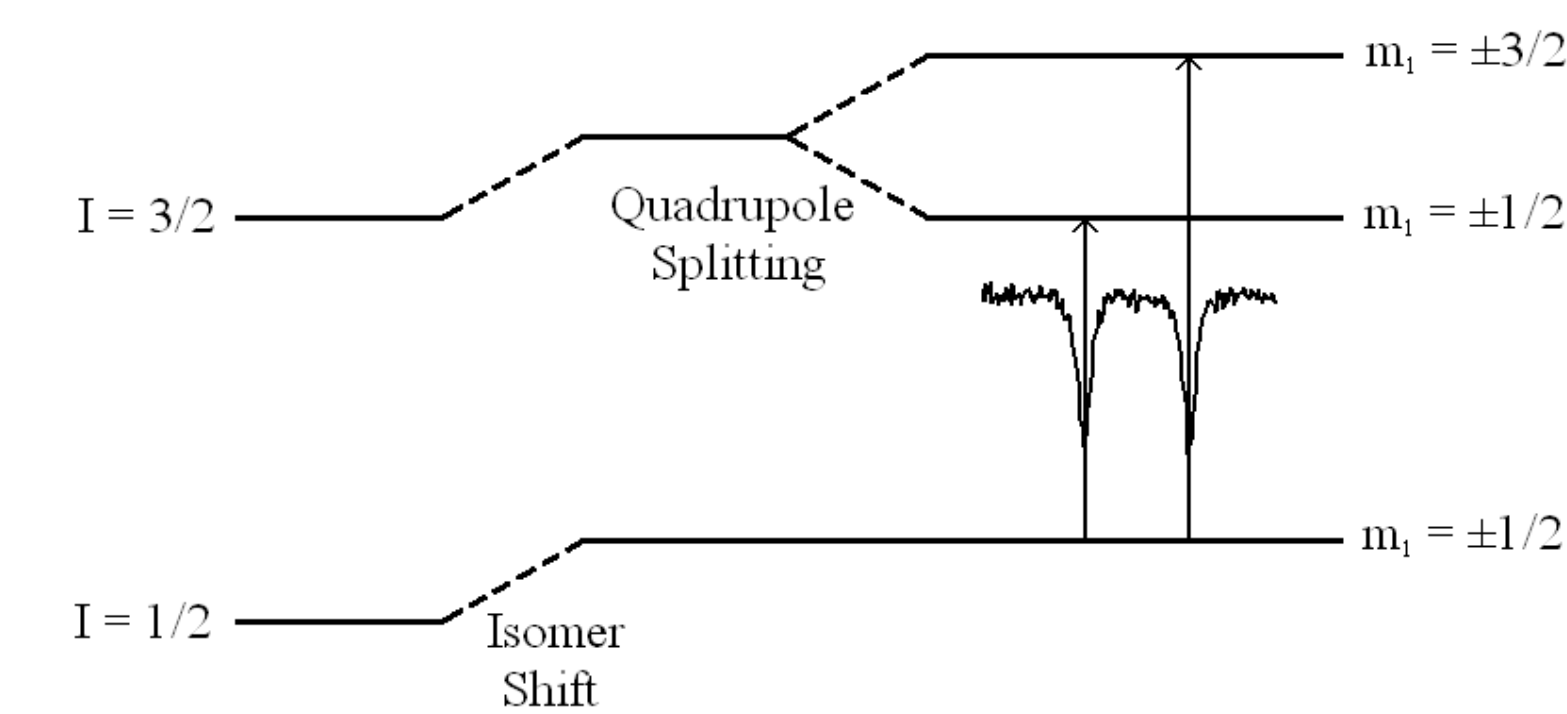

Figure 2: Energy level diagram showing the isomer shift and quadrupole splitting for the 3/2 to 1/2 transition in  $^{57}\text{Fe}$ .

## Magnetic Splitting

Magnetic splitting is caused by the interaction of the magnetic dipole moment of the nucleus with a magnetic field [3]. This effect is illustrated for  $^{57}\text{Fe}$  in Figure 3. Measurements of the magnetic splitting provides information about the magnetic properties of the material.

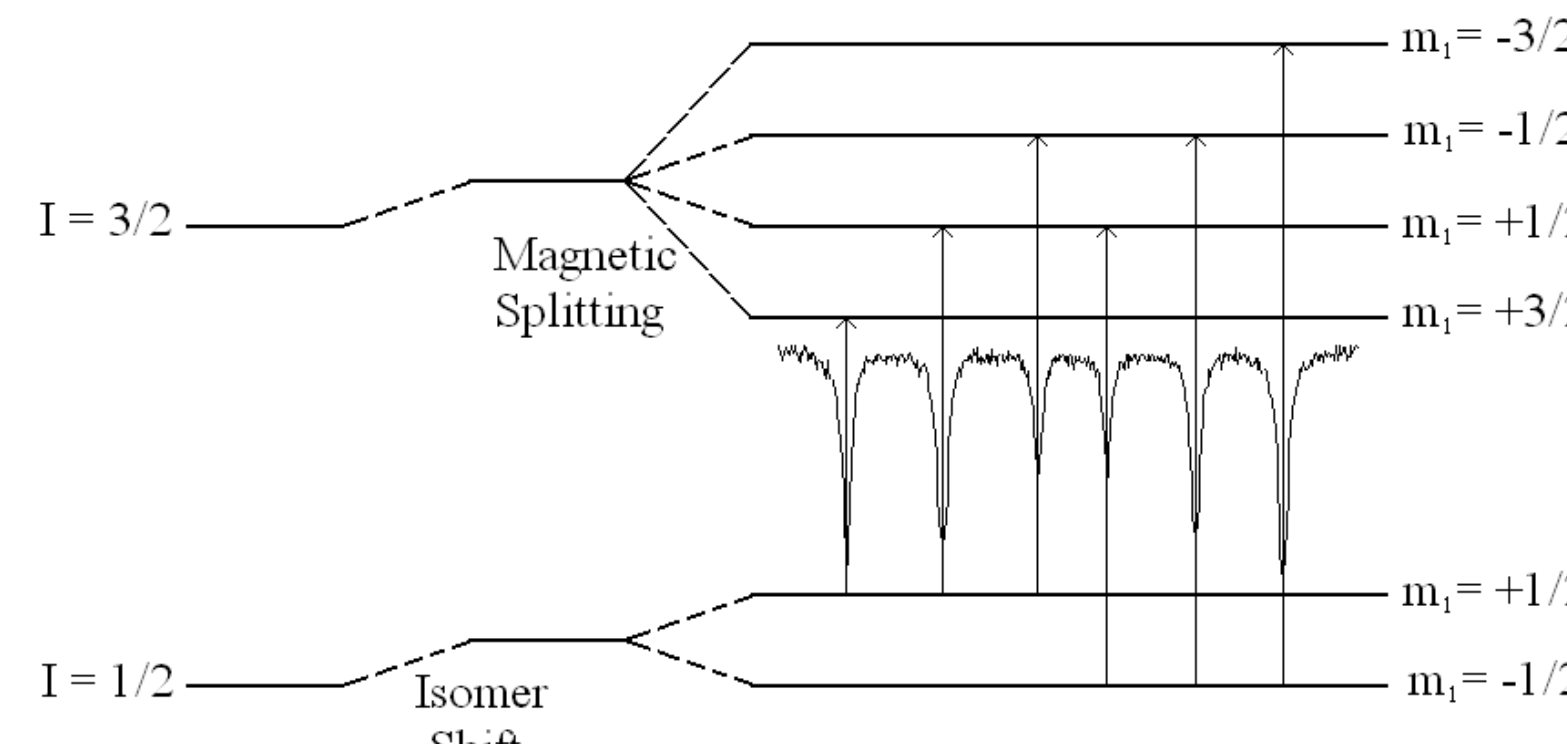

Figure 3: Energy level diagram illustrating magnetic splitting in  $^{57}\text{Fe}$ .

## Our System

Two years ago a student developed a constant velocity system for Mössbauer spectroscopy. Though very useful in demonstrating the Mössbauer effect for upper level lab courses, it has a few disadvantages for research. The data acquisition is slow and data cannot be collected for long periods of time.

We have developed a constant acceleration spectrometer that repeatedly scans a range of velocities and can acquire data more quickly and over much longer time intervals. A block diagram of the system is shown in Figure 4.

The cobalt-57 source is attached to an oscillating linear motor that sweeps over a range of velocities at constant acceleration. A krypton gas counter sits behind the absorber and detects the transmitted gamma rays. The computer counts the gamma rays of interest as a function of velocity and synchronizes the velocity sweep of the linear motor. An energy spectrum of gamma rays from the  $^{57}\text{Co}$  source is shown in Figure 5 with the 14.4-keV peak of interest highlighted.

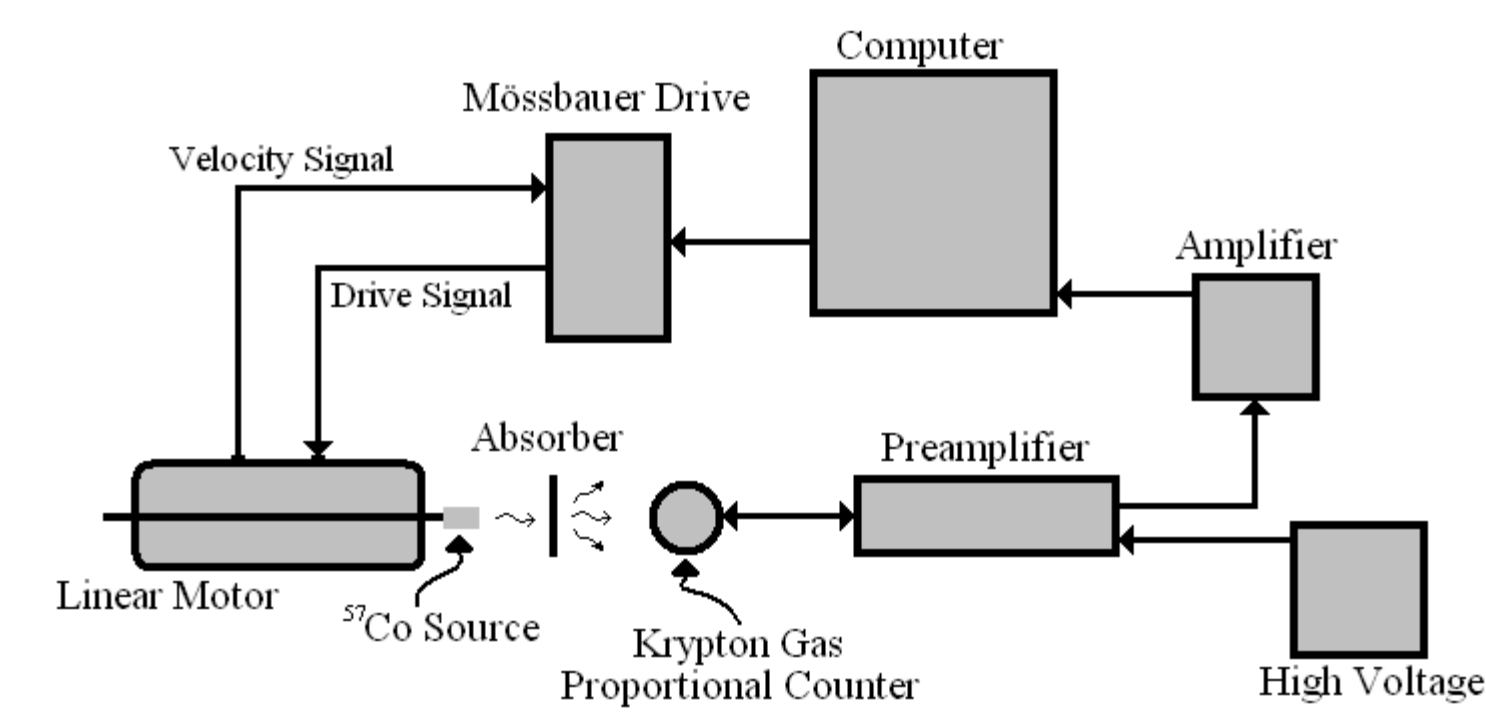

Figure 4: Block diagram of the constant acceleration Mössbauer spectrometer.

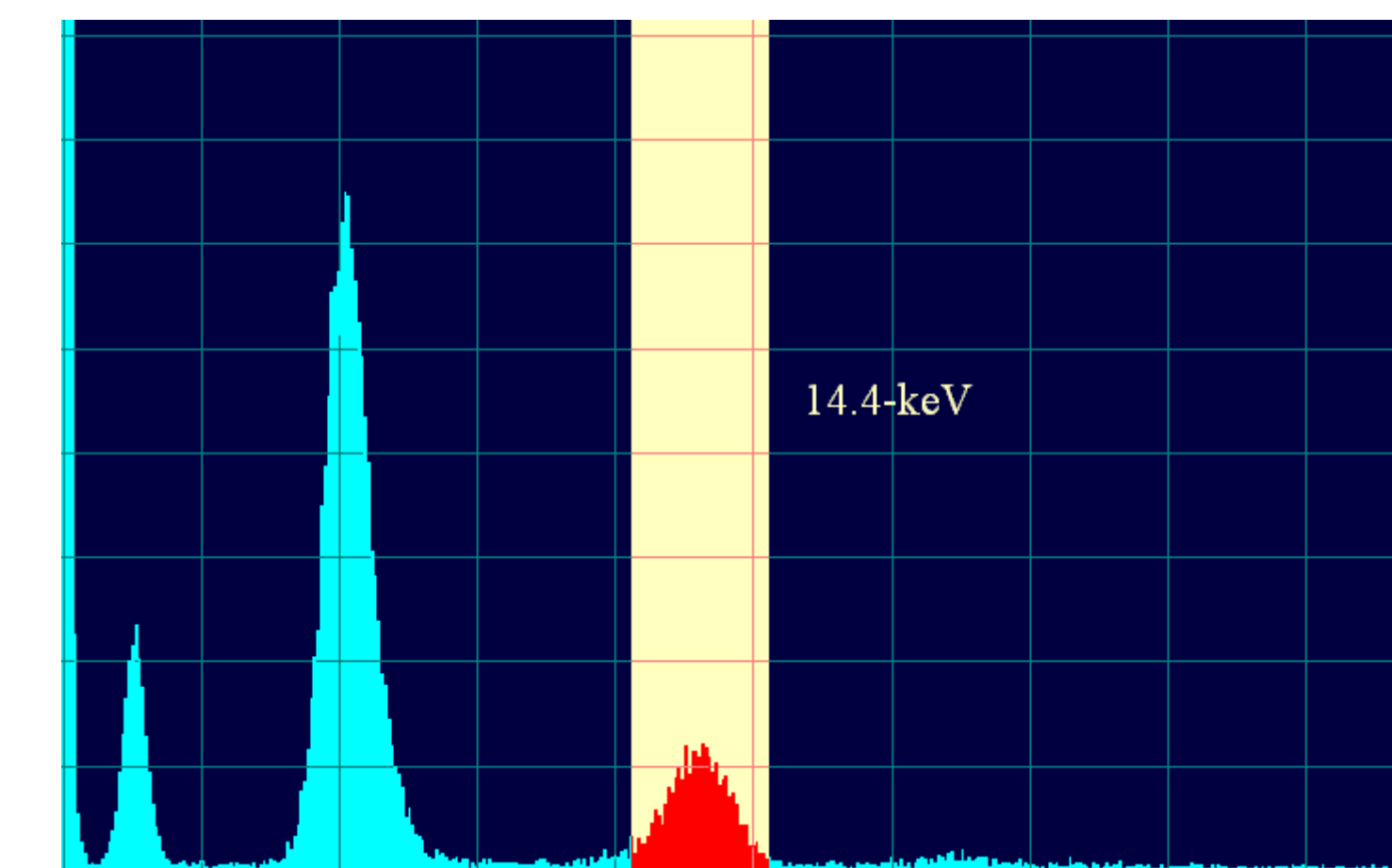

Figure 5: A gamma ray energy spectrum from the  $^{57}\text{Co}$  source with the 14.4-keV peak of interest highlighted.

## Sample Results

Figures 6 and 7 are examples of Mössbauer spectrum taken with our system using standard reference absorbers. Figure 6 is a spectrum taken on a stainless steel absorber illustrating the isomer shift. Shown in Figure 7 is a Mössbauer spectrum of alpha iron demonstrating magnetic splitting. The position of the absorption peaks in alpha iron are well known and can be used to calibrate the spectrometer.

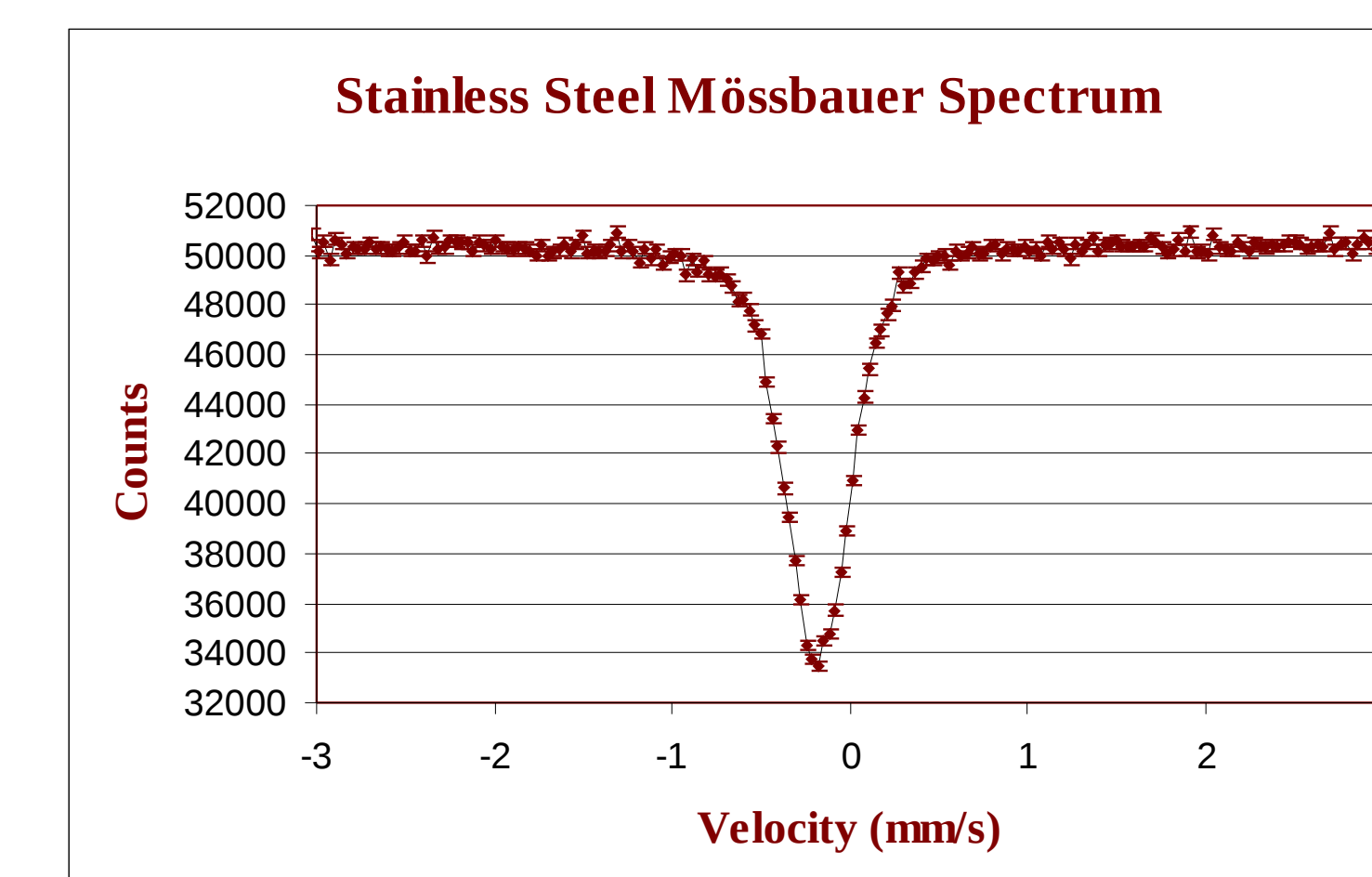

Figure 6: A Mössbauer spectrum of stainless steel.

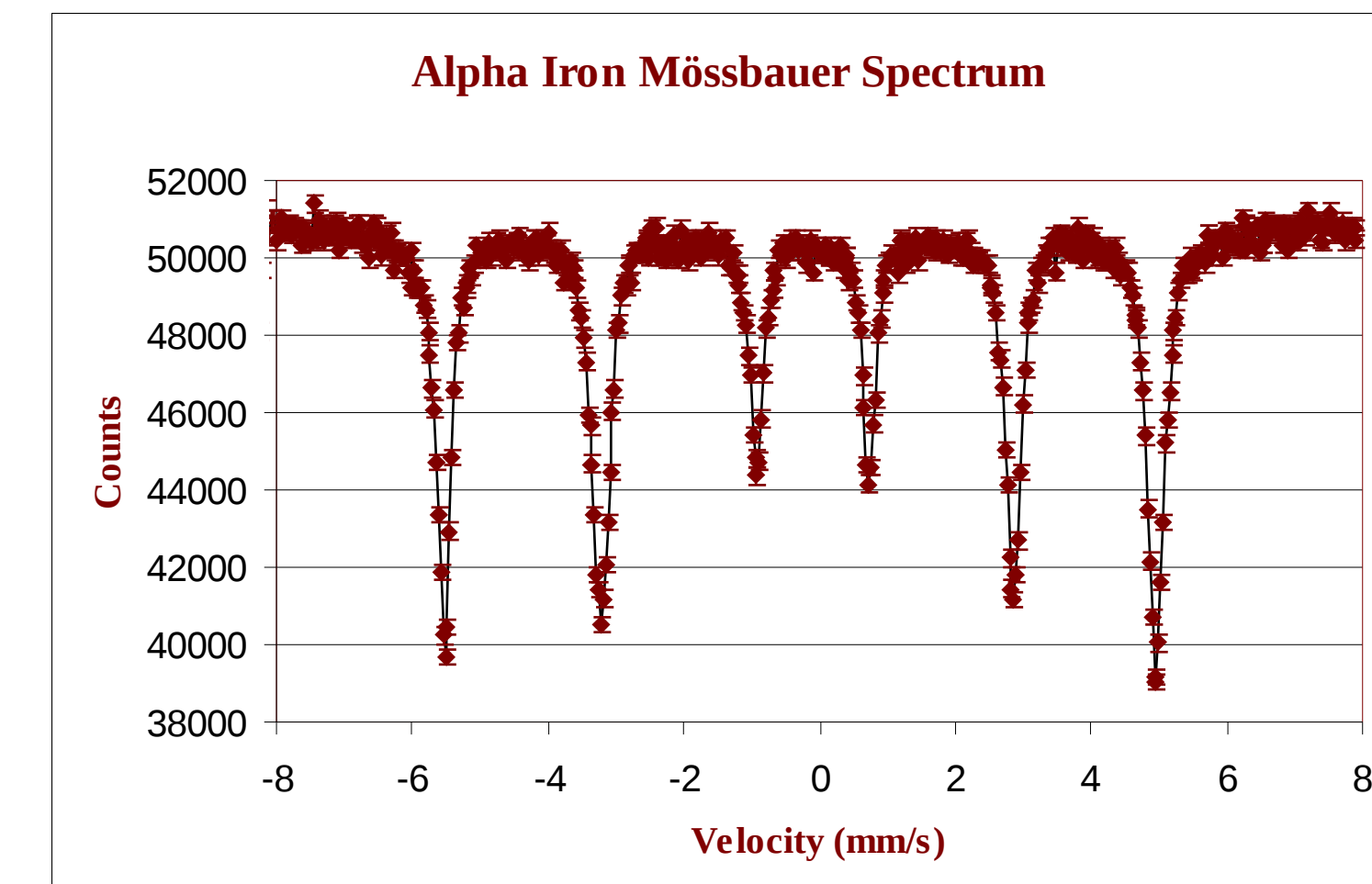

Figure 7: A Mössbauer spectrum of alpha iron.

## Future Work

Future work will include the development of an absolute velocity calibration system using a Michelson interferometer. We also plan to use the Mössbauer spectrometer to study environmental materials.

## References

- [1] Pound, R.V. and G.A. Rebka Jr. “Gravitational Red-Shift in Nuclear Resonance.” *Mössbauer Effect, Selected Reprints*: 75-76.
- [2] “Two Working Mössbauer Spectrometers On the Surface of Mars.” *Mössbauer Effect*. Feb 2004. 28 July 2008 <<http://mossbauer.org>>.
- [3] “Introduction to Mössbauer Spectroscopy.” *Royal Society of Chemistry*. 2008. 23 June 2008 <<http://www.rsc.org/Membership/Networking/InterestGroups/MossbauerSpect>>.
- [4] Murad, Enver, and John Cashion. *Mössbauer Spectroscopy of Environmental Materials and their Industrial Utilization*. Boston: Kluwer Academic Publishers, 2004.

## Acknowledgements

I would like to thank Union College for financial support in the form of a McMath Summer Fellowship, Professor Mike Vineyard for his guidance, and the Department of Physics and Astronomy for providing other resources.

